

NO.	REVISION	CHK'D / DATE	DRA'G
A	RELEASED (RD-2022-142)	2022.11.21	JK

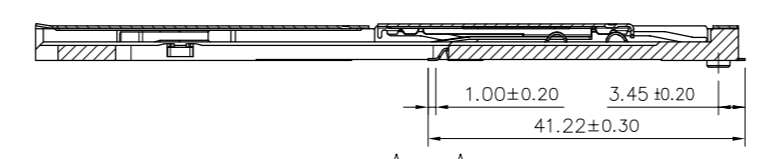

SECTION A-A
SCALE 1:1

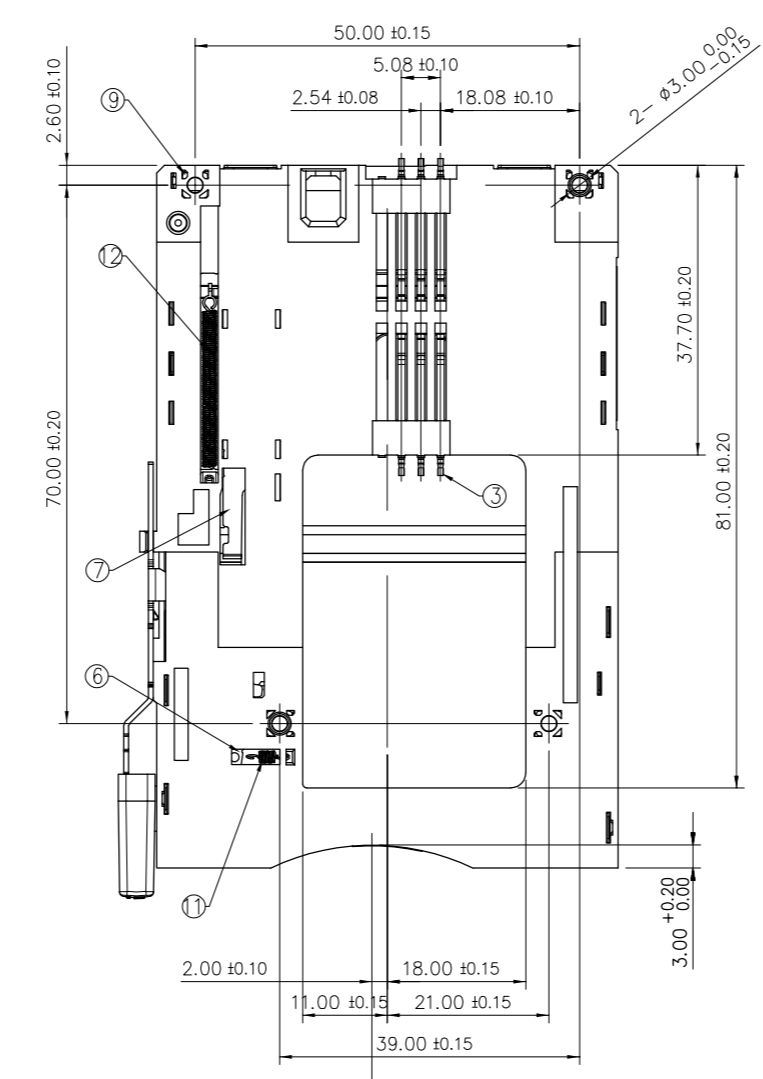
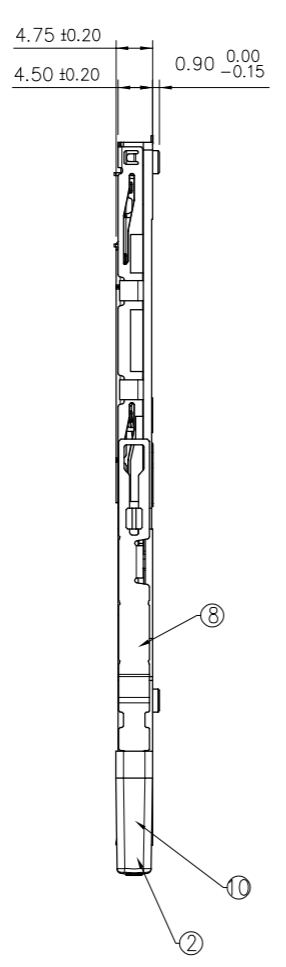
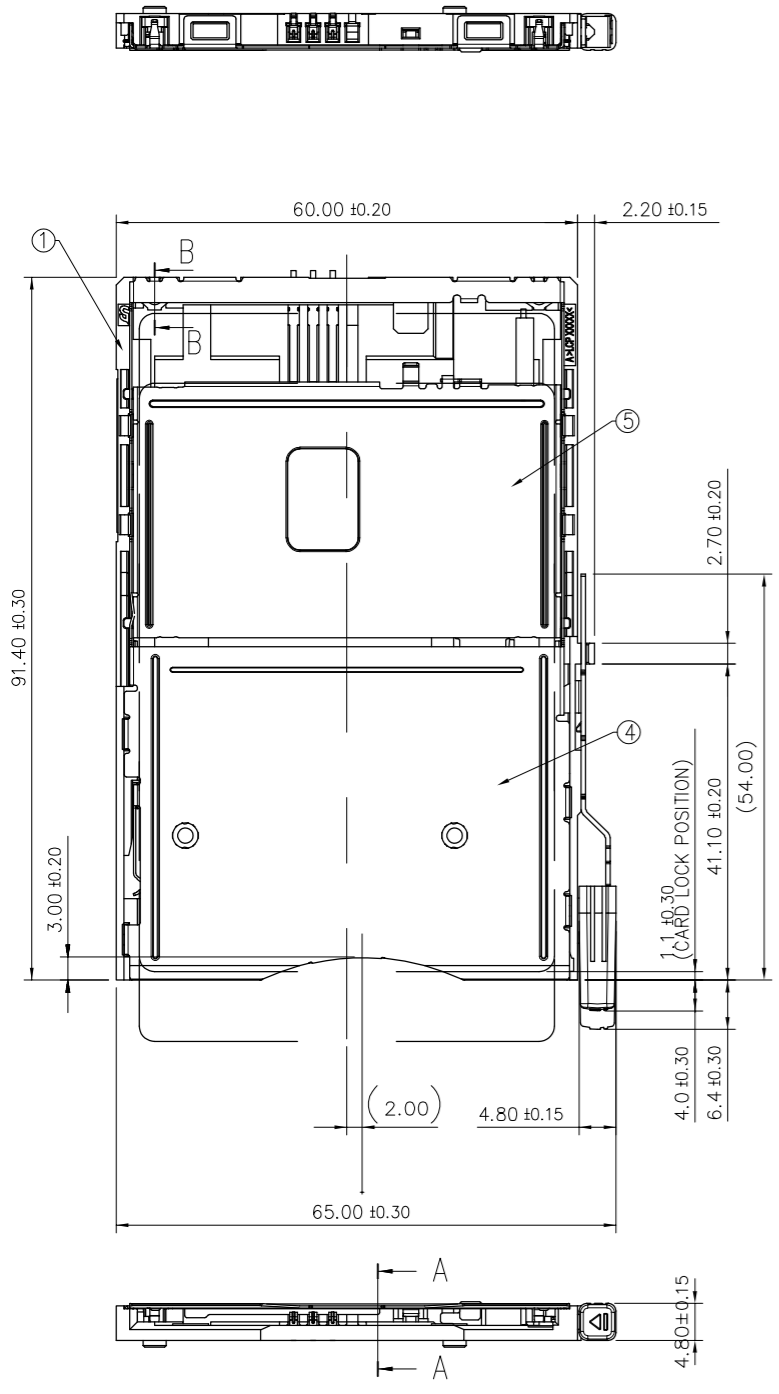
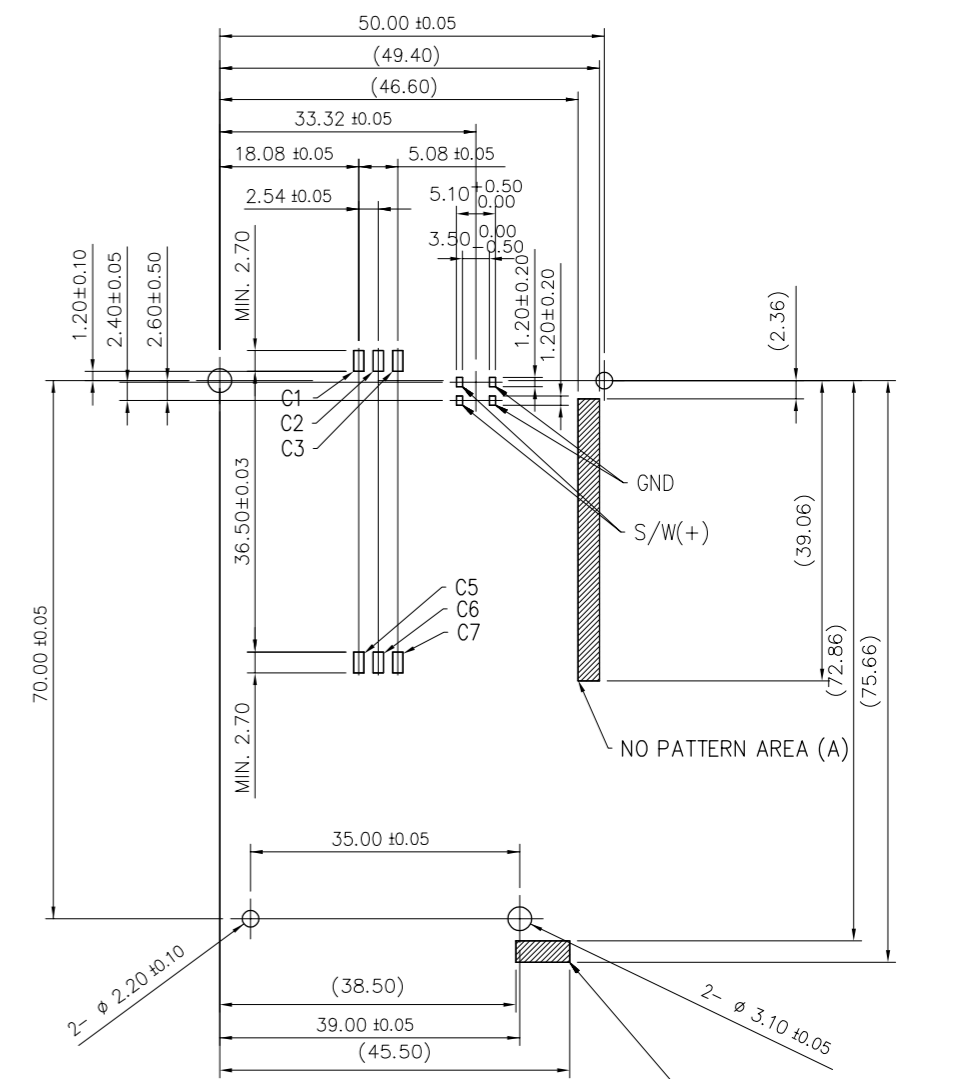

RECOMMENDED P.C.B PATTERN
SCALE 1:1

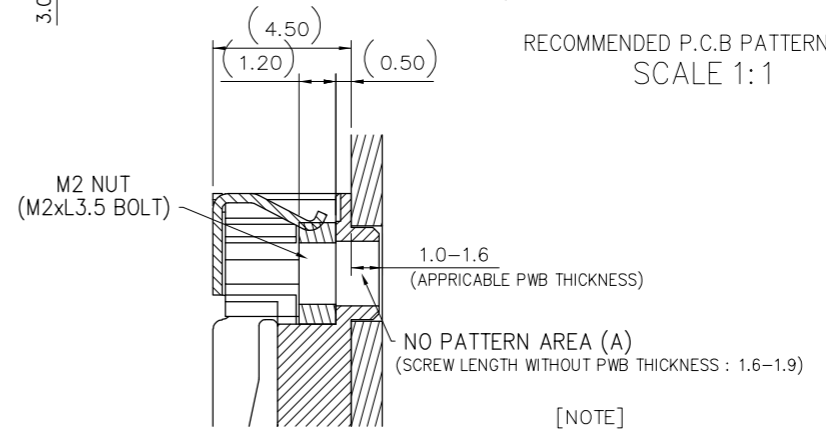

SECTION B-B
SCALE 4:1

- [NOTE]
1. Weight : 26.5g (±2.7%)
 2. NO RUST, CONTAMINATION, DAMAGE NOR DEFORMATION EFFECTING ON FUCTION (제품 기능 및 성능에 유해한 Burr, 변형, 휨, 이물질 등이 없을 것.)
 3. LEAD CO-PLANARITY (LEAD 평탄도) : MAX 0.20mm (0.20mm 이하)
 4. Logo 및 Cavity는 음각으로 표시.
 5. '*' 는 중요 치수

(PART LIST)

No.	PART	MATERIAL	Q'TY	FINISH
1	BASE INSULATION_1	LCP-(GF+MD)35	1 EA	BLACK
2	EJECT BUTTON	PA46	1 EA	BLACK
3	CONTACT TERMINAL	COPPER ALLOY	6 EA	Au OVER Pd-Ni OVER Ni
4	COVER FRAME_1	SUS304 T0.3	1 EA	
5	SLIDER_1	SUS304 T0.35	1 EA	
6	LOCK PLATE	SUS304 T0.4	1 EA	
7	EJECT PLATE	SUS304 T0.4	1 EA	
8	EJECT BAR	SUS304 T0.6	1 EA	
9	NUT	SPCC	4 EA	Ni PLATING
10	EJECT SPRING	SUS	1 EA	-
11	SPRING A	SUS	1 EA	-
12	SPRING B_2	SWC	1 EA	Zn PLATING

* ㉠ 표기된 MS는 최신 리비전을 적용할 것.
(MS MARKED AS ㉠ MUST MEET THE LATEST VERSION)

SPEC NO	REV	SPEC NAME
MS201-02	㉠	유해 물질 금지 및 신고 - 부품 및 재료 Prohibition and reporting the use of harmful substances - parts and materials
MS300-08	11	표준 시험 방법 - 내장재 연소성 Standard test method - flammability resistance for interior materials
MS300-34	13	내장재의 냄새 시험 방법 Test method of odor for interior materials
MS300-55	11	부품의 VOCs 방출량 시험 방법 Test method for the determination of the emission of VOCs from vehicle part

DATE	2022.11.21	SCALE	1:1	(주)우주 일렉트로닉스 UJU Electronics co.,Ltd.
MATERIAL	SEE NOTE	REVISION NO.	A	
FINISH	SEE NOTE	TITLE	Card_Socket	
GENERAL TOLERANCE	0.0 : ± 0.30 0.00 : ± 0.20 0.000 : ± 0.10 ANGLE : ± 1'	PART NAME	OHCL_ETCS_Card_Socket	
DRAWING	DESIGN	CHECK	APPROVAL	
JK. HWANG			SJ. LEE	
TRIGONOMETRY		UNIT	mm	
		SIZE	A3	
		SHEET NO.	1 OF 1	